

Focus on your welding performance

Get accurate gas mixtures

Whatever your consumption, whatever your flow rate, the Dynamic On-site Mixer delivers a consistent welding gas from liquid supply.

Get the highest reliability

A smart robust design that requires no power supply, no solenoid valve, no buffer tank.



Contact Us

Air Liquide Polska Sp. z o.o.
ul. Jasnogórska 9, 31-358 Kraków
tel.: +48 12 627 93 00
e-mail: airliquide.polska@airliquide.com

www.airliquide.com/poland



A world leader in gases, technologies and services for Industry and Health, Air Liquide is present in 75 countries with approximately 66,400 employees and serves more than 3.8 million customers and patients.



DYNAMIC
ON-SITE MIXER

Always mixed right

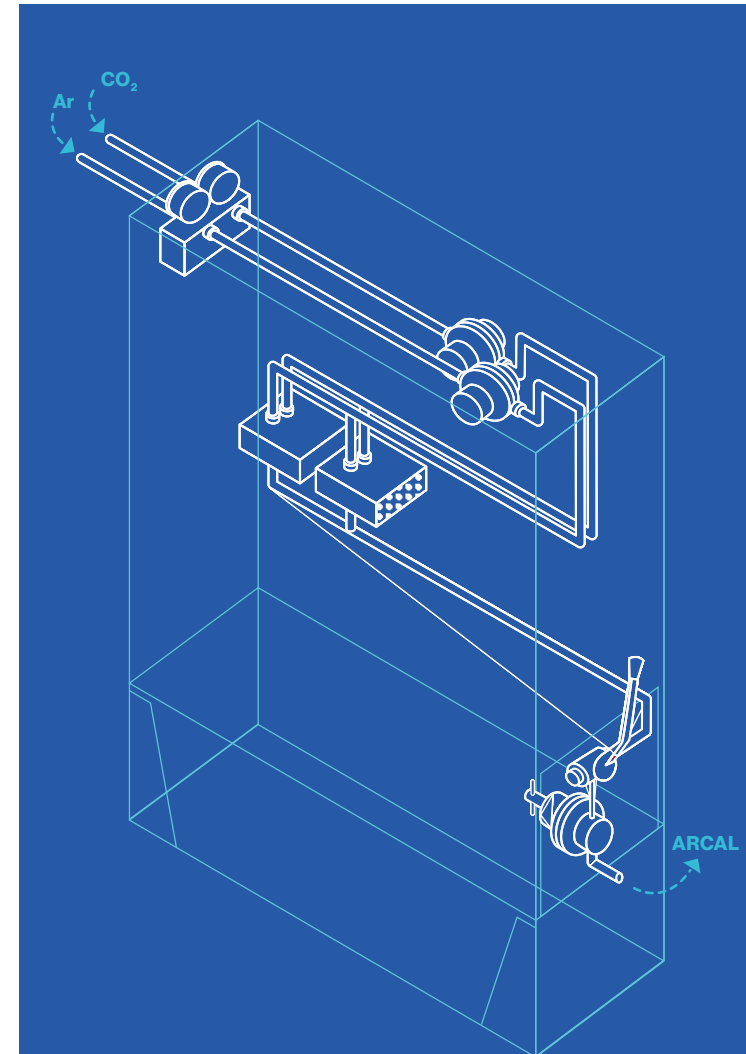

The dynamic on-site mixing solution for the best welding gas quality

Smart & compact

- Easy to use
- No buffer tank needed
- Installation and maintenance performed by Air Liquide

Robust design

- Fully pneumatic system for optimal reliability
- No power supply, no solenoid valves
- Validated for outdoor installation from -40°C up to +50°C



Stable & Consistent mixtures

- Fixed composition: no calibration on-site required
- No deviation of the composition whatever your flow rate
- No need of an analyzer

Adaptable equipment

- Standard units available:
 - Mono-mix with one fixed gas composition
 - Dual-mix with two outputs of different fixed gas compositions
 - 50 m³/h and 100 m³/h max flow rate
- Units can be combined to refine your needs

Designed for **ARCAL™**

Premium mixtures for welding

- Compliant with ISO 14175
- Available for all **ARCAL™** reference mixtures:



- Also available for a list of technical products:
 - **ARCAL™ M13** M13-ArO-2
 - **ARCAL™ M14** M14-ArCO-3/1
 - **ARCAL™ M23** M23-ArCO-5/4
 - **ARCAL™ M24** M24-ArCO-12/2

Welding performance

- Performance validated by Air Liquide R&D and assessed by users worldwide!
- From 1 L / min up to maximal output flow, gas composition remains constant

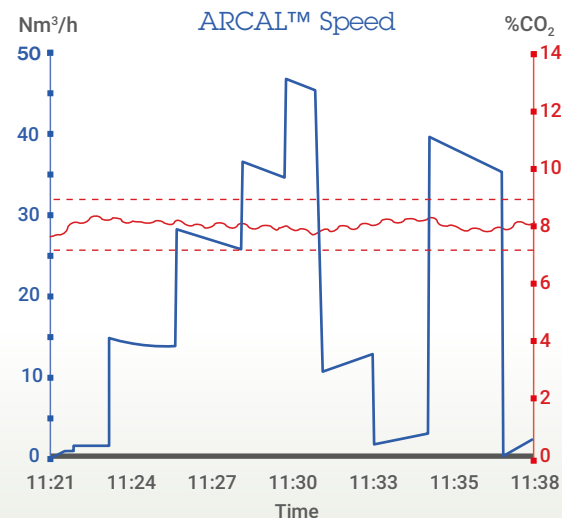

Benefit from Air Liquide expertise in liquid supply

Quality of liquid products

- A strict control of raw products notably with ARCAL™ Prime for Argon and ARCAL™ C for CO₂
- The Air Liquide solution with liquid supply and dynamic on-site mixer ensures the same quality as welding gas products in cylinder

World class logistics

- Compliant with the most stringent safety standards
- Flexibility and reliability of liquid supply ensured by Air Liquide large fleet and infrastructure
- Compatible with all types of storage tanks, including Skid Tank

